

INSTALLATION INSTRUCTIONS: A-Series Domestic Roller Doors

NOTE: Please carefully read all instructions before commencing installation.

1. Brackets must be absolutely level.
2. Ensure the door curtain overlaps equally each side of the opening.
3. The back of the lintel must be flush with the back of the door post (where the brackets and guides are fixed).
4. Do not apply grease or oil in the side guides.
5. If you decide to paint your roller door it is advisable to also paint the top of the roll inside the garage (raise the door and paint from the inside of the garage (raise the door and paint from the inside of the garage).
6. Be sure to follow the Maintenance and Care advice to ensure your roller door maintains long term good condition.
7. When installing a Colorsteel® roller door the removable protective plastic film should be left in place until installation is complete. It should be removed immediately following correct installation.
8. Fixings: TEK screws are the standard timber fixings supplied with your roller door. For masonry installation you should use masonry anchor fixings (not supplied) - for brackets use 10mm anchor bolts and for guides use TEK screws with fibre plugs or anchor bolts.

FRAMING AND CLEARANCE DETAIL

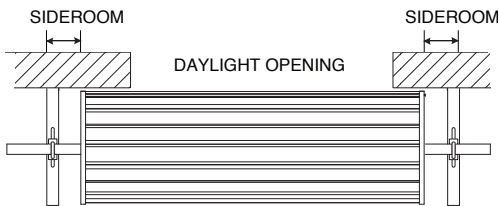

SIDEROOM: Hand operation: 85mm minimum. Motorised operation: 135mm minimum on motor side dependent on brand of auto opener.

FLOOR REBATE: Allow 85mm into opening and extended 65mm each side behind door posts. Rebate depth 25mm.

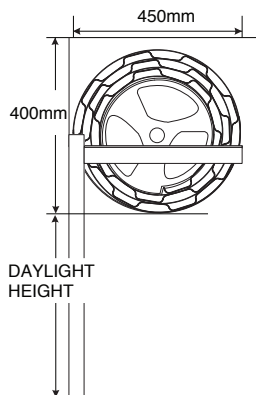
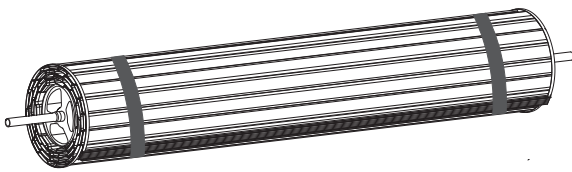

All parts including guides should be removed from the end and inside the door roll.

DO NOT CUT THE BANDS, which hold the door in a roll until advised in the instruction.



WARNING: No guarantee will be given or responsibility accepted by the manufacturer if the door is not installed and maintained as instructed. For satisfactory operation of your Roller Door follow all instructions carefully.

STEP 1:

- With door on ground loosen steel anti-collars on both ends of axle, hard against plastic drum wheels. Firmly grasp the axle in both hands and rotate as far as possible then release quickly. Repeat two or three times. Then immediately fit steel anti-coning collars hard against plastic drum wheels and tighten firmly.
- Mark out the door curtain width across the back of the opening, equalizing the excess width each side.
- Firmly secure one bracket with TEK screw and large washers.

STEP 2:

- Using a water level or a straight edge and spirit level transfer position of the top of the first bracket arm to opposite side of opening, then mark drill and fix second bracket. Select from the parts bag 2 U-bolts, 2 saddle-clamps, 4x8mm nuts and spring washers.

STEP 3:

- Lift the rolled-up door on the support brackets with the saddle positioned underneath the axle. If the side clearance is not available cut the axle to suit.
- Fit U-bolts, washers and nuts over axle into slotted adjustment holes provided in each support bracket. At this time centralise the door with the door opening **moving both axle and door together**. This will avoid uneven rolling in operation. Care taken when positioning the door here will avoid further adjustment at a later stage.

STEP 4:

- Secure the axle to the support brackets with the U-bolts and nuts. **LOCK VERY TIGHTLY** using washers under the nuts. **SPRING TENSION WILL BE LOST IF THE AXLE IS NOT CLAMPED FIRMLY.**
- Apply tension to the springs by rotating the door approximately 1.5 turns in the direction of the arrow as illustrated. The amount of tension to give best operation may vary with individual doors. Final adjustment can be made after completion of insulation.

STEP 5:

- While holding the door in its tensioned position cut bands which hold door in a roll and pull curtain partly down as illustrated.

WARNING: At this stage door may have a strong tendency to rise and unroll which if uncontrolled could cause damage. Therefore it must be securely held in position until guides which incorporate head stops are fitted. A chock for holding door in position can be made out of a piece of softwood as shown. Use care when placing chock between curtain and roll to avoid possible damage.

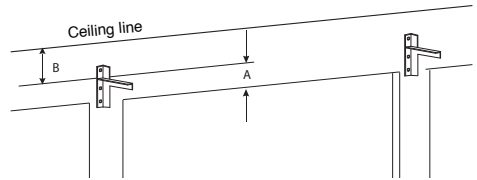

NOTE: The necessary clearance between edge of curtain and brackets is 10mm minimum and 100mm maximum, bracket arm height above the lintel should be 150mm (A), the necessary clearance required above the bracket arm to accommodate the door roll is 230mm minimum (B).

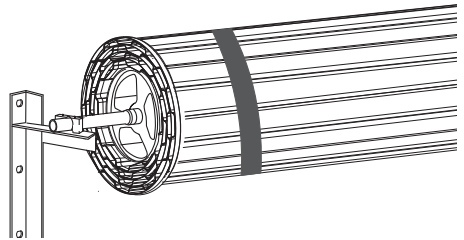

- Ensure there is sufficient clearance between the door roll and back of the lintel when the door is rolled around on the axle.

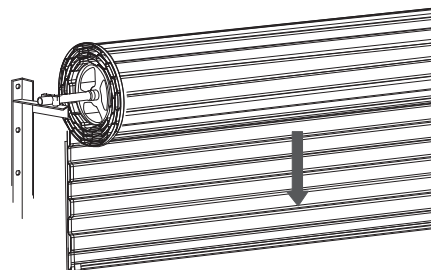
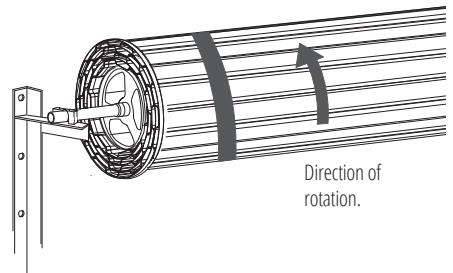

STEP 6:

- Prepare the guides for fixing to door posts using top stops in parts bags.
- Check the length of guides. The overall guide length should be equal to the height from floor to the horizontal arm of the bracket.
- Cut excess length from bottom of guides.
- Slide an even number of adjustable guide fixing lugs (in parts bag) into each guide from bottom.

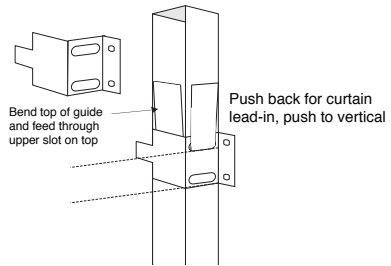

STEP 7:

- With the door still centralised, slide one guide over the edge of door curtain.
- Fix in place using 'TEK' screws or suitable masonry anchors with the fixing lugs spaced with top lug 200mm below top stop and bottom lug 100mm from floor and others evenly spaced between.
- This guide must be placed in a true vertical position regardless of door post position to which it is fixed.
- Remove wooden chock.
- Holding bottom rail section of door firmly against this guide, fix top of other guide.

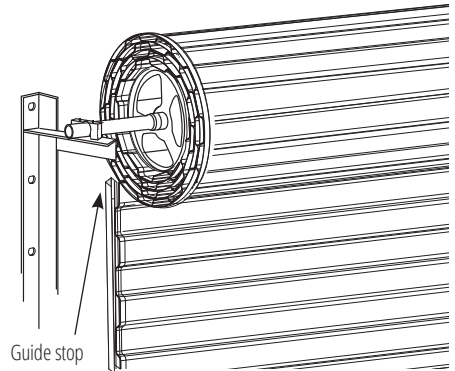

IMPORTANT: 6mm clearance with guides must be allowed as working clearance for door curtain when operating. Draw curtain down and fix centre of this guide as above and again for bottom of the guide. Check operation of door to ensure there is no scraping or binding of door in guides.

STEP 8:

KEYLOCKING:

- With door in closed position (firmly seated on floor) mark the points of contact between the lock arm bars and inside back of guides.
- At this mark drill a series of holes and file out a slot slightly larger than the lock arm bar. Ensure a neat fit.

PADBOLTS:

- Fit to each side (inside of door curtain) in the first full profile from floor level.
- Ensure fixing position allows slide bolt to protrude sufficiently through guide in locked position.
- Mark slide bolt contact points with inside of guides and prepare hole slots for keylocking above.

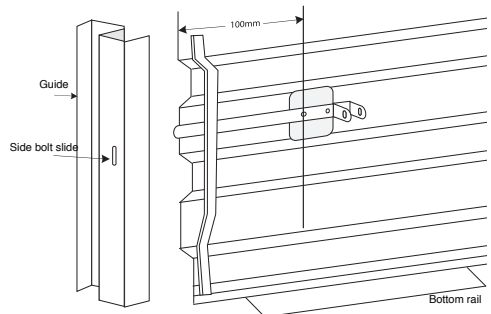

STEP 9:

To conform to manufacturers specifications all 'A' and 'B' series roller door curtains must be "pinned" as per diagram shown at right.

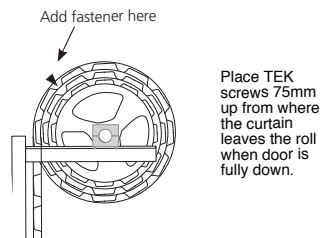

STEP 10:

Test operation of door. Adjustment of spring tension may be necessary. Follow procedure below.

Do not apply oil or grease to assist operation.

- 1) If the door rolls up crooked and the bottom rail does not look parallel with the door roll or the edge if the roll is not flush (that is, the door rolls in a cone shape) check a) bracket levels, b) axle is centralised. To centralise the axle: with the door rolled up and a firm hold on the axle with a pipe wrench, loosen the 'U' bolts and anti-coning collars and move the axle sideways 10mm at a time, in the direction of the arrow. Move the axle distance 'x' in diagram. Retighten 'U' bolts and anti-coning collars. Extreme care must be exercised.
- 2) If the door is hard to operate in EITHER DIRECTION, check the door is not jamming in the guides.
CHECK:
 - a) the guide clearances
 - b) that guides are plumb
 - c) that the guide surfaces are clean and free from oil, dents etc
- 3) If the door is hard to operate in ONE DIRECTION, the spring tension requires adjustment (see diagram)
 - a) If the door is hard to lift, but tends to drop then increase the spring tension
 - b) If the door is hard to close but tends to rise, then decrease the spring tension
- 4) If the door is stiff to work or rattles over in on top of guide:
 - a) check that guides are not too long
 - b) Loosen one 'U' bolt and push that side of door towards opening as far as possible without scraping lintel. Tighten the 'U' bolt and repeat operation with the other side, ensuring that the axle is still parallel with opening.
 - c) Check if guide is twisted out of square. If so pack out top lug of guide.

SIDEROOM

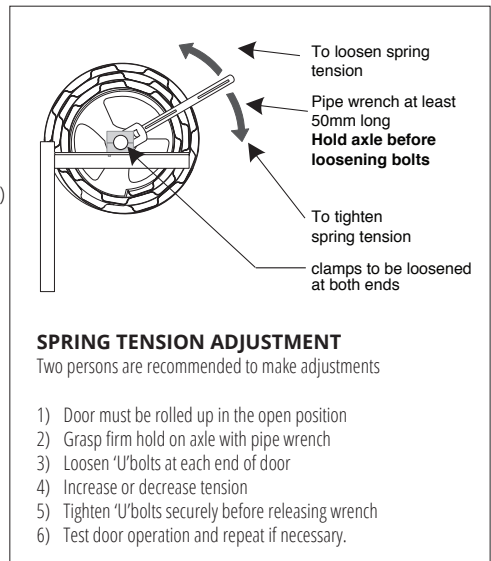
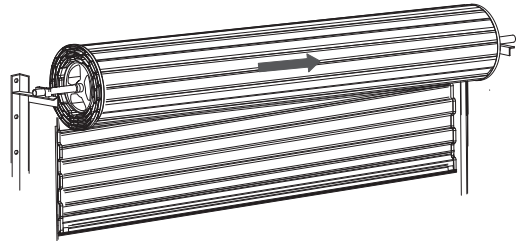
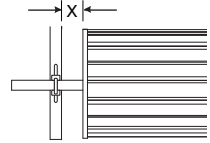

MAINTENANCE AND CARE OF YOUR ROLLER DOOR:

To avoid the potential corrosion affecting the roller door curtain be sure to wash with soapy water and a soft brush (rinse with clean water) several times a year. If your door is located close to coastal, geothermal or industrial areas your door should be cleaned more often. When cleaning pay particular attention to the curtain behind the lintel and over the top of the door roll. From time to time clean the inside of the side guides with a spirit cleaner and apply a dry silicone spray.

DO NOT oil the door lock.

DO NOT apply oil or grease to the inside of the side guides.

DO NOT raise the door with the key in the centre lock.

WARRANTY

Provided the door is installed with these instructions and maintenance advice followed, the manufacturer warrants all parts and performance for a period of three years.